

The Rx5 Series Radio Remote Control receiver/decoder is intended for use with matching 1/2/3/4 button transmitters and can provide either relay (Volt Free contacts) or MOSFET (Open Drain, non isolated) outputs.

Installation & Use

These units are intended for use in light industrial, commercial or domestic environments. For best performance the receiver and its antenna should be mounted at least 1 metre away from potential sources of electromagnetic interference such as other RF transmitters or 'noisy' electronic devices such as PCs or switch mode power supplies.

Remove the case lid (if supplied) and refer to the diagram showing the layout of the board. Connect an external power supply (12 - 16 Volt DC max) to the power connector observing polarity. N.B. The unit is protected from reverse polarity connection. Additional terminals are provided to link power to the outputs if required.

Do not connect any loads to the outputs at this stage.

Apply power and check that the red status LED (1) blinks every 1/2 second. This indicates that the board is powered, 'healthy' and is operating correctly.



Cased Receiver and Four-Button Transmitter

Coding

The receiver uses a 'learning' decoder to save and then recognise a specifically coded transmitter, which should have been previously set up (see transmitter instructions). It is 'programmed' by pressing and holding the 'LEARN' push button switch on the receiver and simultaneously pressing any transmitter button. During this operation the green status LED (2) will flash indicating that the transmitter code has been saved.

When the 'LEARN' switch is released the green status LED (2) will again flash indicating that it now recognises the transmitter code. The red LED (1) will now also light and the selected outputs will become active (On) for the duration of the transmission (momentary action) dependant upon which transmitter button has been pressed.

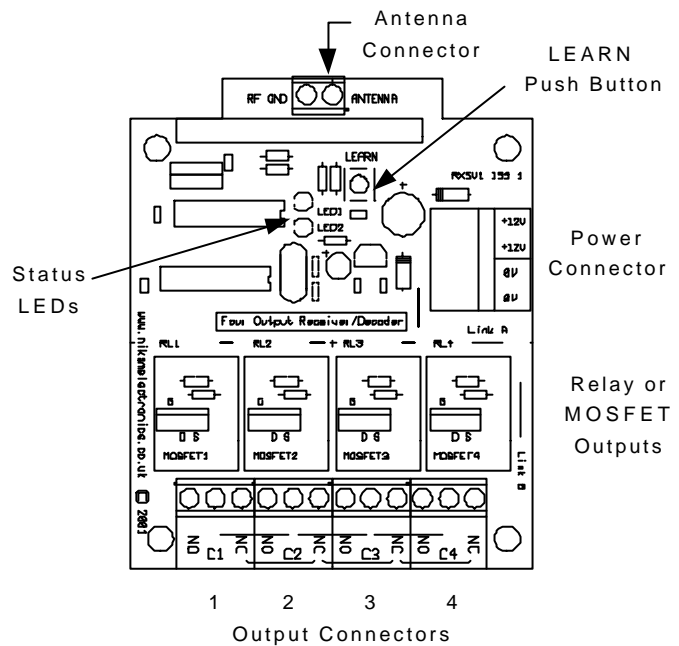

Connection of Loads

The relay output version provides Common (C), Normally Open (NO) and Normally Closed (NC) relay contacts which are identified on the boards. The numbered outputs (RL1,2,3,4) normally correspond to the transmitter buttons.

The relay outputs are electrically isolated from the rest of the board but the usual precautions should be taken when connecting to mains voltages.

The MOSFET output version (see diagram) has electrical links that connect to the board power supply thus providing non electrically isolated Open Drain outputs from the NO terminal that switch to 0 Volts (Ground).

Rx5 Board Layout

Observe the maximum load currents that can be switched by the output devices (See specifications). Note that short circuits or wiring errors may cause destructive damage to the board and devices. For inductive loads it may be necessary to fit additional suppression components.

Antennas

The performance of a radio system is dependant upon the antennas and their location. The wire 'whip' antenna (150mm) will only provide optimum performance if it is in 'free space' away from any other conductive materials. Keep other connections to the receiver away from the antenna. A suitable external antenna can be connected to the Antenna connector via a low loss 50 Ohm coaxial feeder cable.

Specifications

Receiver Type	FM/FSK Dual Conversion Superhet
Frequency	433.920 MHz +/- 30KHz
Antenna	150mm Whip for 433.92MHz
Decoding	'Learning' with address saved in non volatile EEPROM
Status Indication	On board LEDs for Power, Valid Code and Learn function
Power	External 12V –16V DC only. 20mA quiescent current 160mA max (4 relays on)
Outputs	Volt-Free Changeover Relay. 250V AC 5 Amps max current Momentary action to match transmitter button pressed. Fitted with 1-4 relays to match transmitter supplied
Option 2	Power MOSFET 2A DC max. Open Drain Non-isolated
Connection	Screw connectors for relays and power input
Board Size	100 x 80 x 30mm
Case	Grey ABS (The board can be supplied without case)
Case Size	115 x 90 x 55mm (excluding Antenna)
Mounting	Lid removes to reveal mounting holes
Environment	Case sealed to IP65 for Industrial use
Range	200 metres typical for 433MHz combination
Approvals	When operating on 433MHz the units can be used anywhere within the European Union and are compliant with the requirements of the RTT&E directive. 418MHz versions for USA. (Require FCC Approval)
Part No	TxRx5 Series. Customer Options have specific Part Numbers

MOSFET Output Version

Connect the load between the Normally Open (NO) terminal on the connector (connected to the MOSFET Drain) and the positive supply as shown in the diagram. The MOSFET output is equivalent to a switch that connects to 0 Volts.

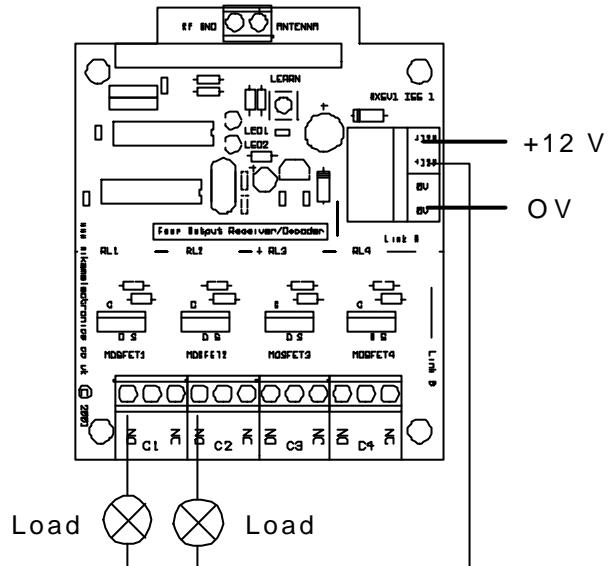

Copyright

The information contained in this data sheet is the property of nikam electronics and copyright is vested in them with all rights reserved
Copyright law also protects the circuitry, microprocessor firmware and design of the boards.

Disclaimer

nikam electronics has an on going policy to improve the performance and reliability of their products, we therefore reserve the right to make changes without notice. The information contained in this data sheet is believed to be accurate however we do not assume any responsibility for errors nor any liability arising from the application or use of any product or circuit described herein. This data sheet neither states nor implies warranty of any kind, including fitness for any particular application.

Warranty

The receiver is guaranteed against defective components or workmanship for a period of 12 months from the date of purchase. The product under warranty will be repaired or replaced free of charge providing that damage or malfunction has not been caused by incorrect electrical connection, overload, tampering with components, unauthorised repair or modifications, water or chemical contact, lightning or power surges.

nikam electronics

West End
Fairford
Gloucestershire
GL7 4JB
Tel: +44 (0)1285 713862
Web: www.nikamelectronics.co.uk