

Description

The EZ1 board provides a 'transistorized' relay that can be driven from 5-12 Volt logic signals. In addition a 5 Volt regulated output is provided to power signal conditioning or drive circuitry. The board can be operated from either a 12-16V DC supply or a 12Volt AC (transformer) supply. The current required will be dependant on the relay coil resistance but is typically 75mA when the relay is On.

Circuit Diagram

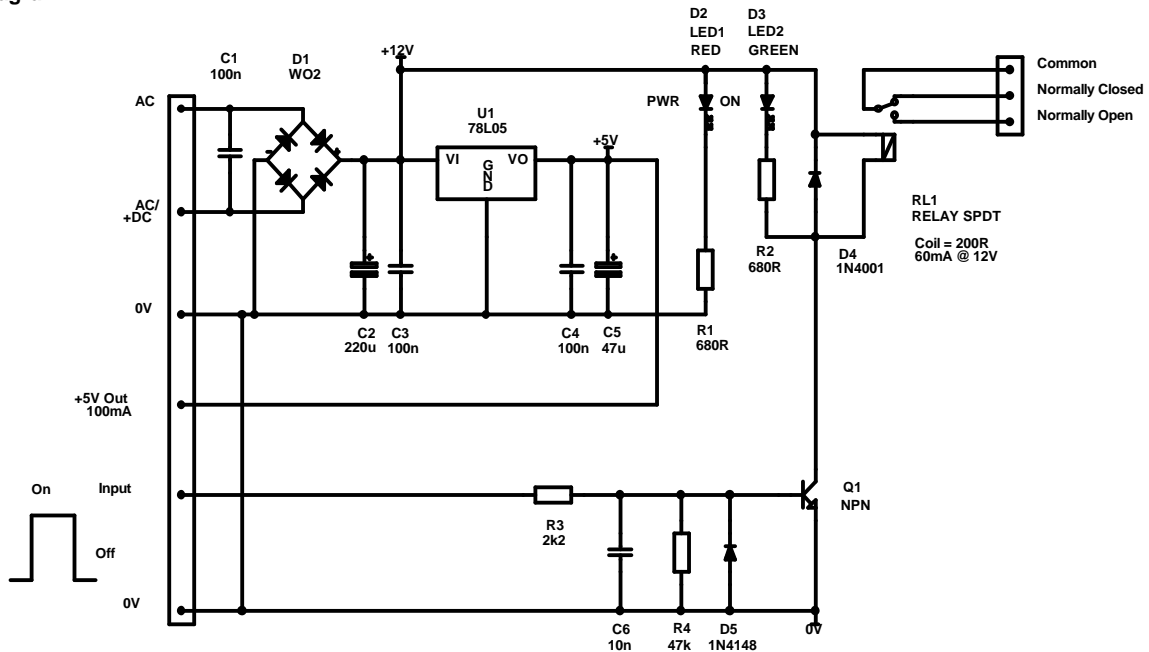

Component Layout

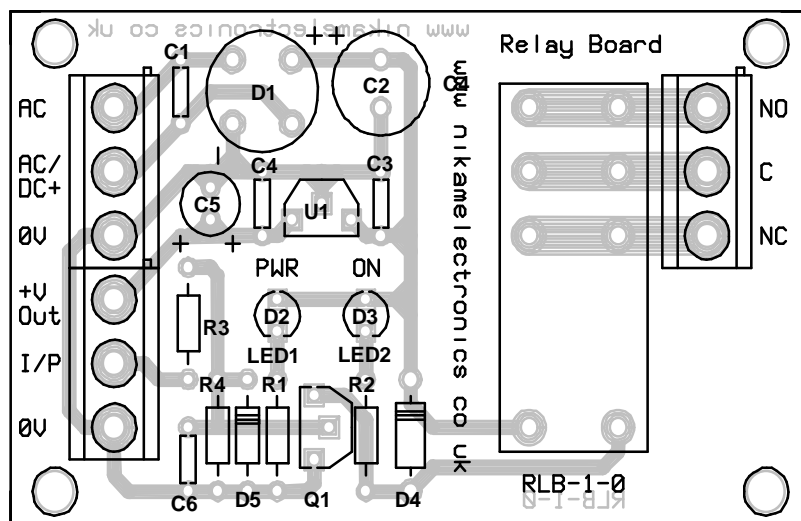

Notes

When operating from a DC supply use the AC/DC+ terminal for the positive supply and 0V terminal for 0V (Ground)
 When operating from a low voltage AC supply (transformer) use the AC input terminals only.

The 78L05 regulator can supply a maximum of 100mA.

Input signal should be 'logic' level – typically 0V to +5V DC. Logic 'high' to turn relay on.
 The input is protected against negative input signals by diode D5 and from transient 'spikes' by C6.

Parts List

Reference	Qty	Part No	Description	Notes/Function
U1	1	78L05	5V 100mA regulator	Or other Voltage as required
Q1	1	BC337	GP NPN Transistor Ic = 300mA	Relay driver
D1	1	W02	1A 100V Bridge Rectifier	For AC input option
D2	1	LED1	Red 3mm LED	'Power On' indicator
D3	1	LED2	Green 3mm LED	'Relay Energised' indicator
D4	1	1N4001	1A 100V Power Diode	Relay 'back EMF' snubber
D5	1	1N4148	75mA 100V Signal Diode	Protects transistor base from reverse polarity
R1,R2	2	680R	CR25 1/4W 5% resistor	Sets 'Relay Energised' LED Current
R3	1	2k2	CR25 1/4W 5% resistor	Sets transistor base drive current - dependant on input voltage
R4	1	47k	CR25 1/4W 5% resistor	Ensures transistor is off with no signal
C1,C3,C4	3	100n 50V	Disc Ceramic 5mm pitch	Decoupling capacitors
C2	1	220u 25V	Electrolytic	Power supply 'smoothing' capacitor
C5	1	47u 25V	Electrolytic	Power supply 'smoothing' capacitor
C6	1	10n 50v	Disc Ceramic 5mm pitch	Optional for RC noise/spike filter on transistor base
CON1	1		6 Way 0.2" Pitch PCB Conector	For power supply and signal inputs
CON2	1		3 Way 0.2" Pitch PCB Connector	For Relay outputs

Q1 may be replaced by a Darlington transistor if higher input impedance is required.

Disclaimer

The information contained in this Build-File is believed to be accurate however we do not assume any responsibility for errors or any liability arising from the application or use of any product or circuit described herein. This Build-File neither states nor implies warranty of any kind, including fitness for any particular application.

nikam electronics

Email: enquiry@nikamelectronics.co.uk

Web: www.nikamelectronics.co.uk